

See discussions, stats, and author profiles for this publication at: <https://www.researchgate.net/publication/228878013>

Superconducting Devices for Radioastronomy; First Steps in Chile: SNS-junction Fabrication

Article · January 2010

CITATIONS

0

READS

203

5 authors, including:



J. Luzuriaga

Centro Atómico Bariloche

55 PUBLICATIONS 441 CITATIONS

[SEE PROFILE](#)



Juan Jose Zarate

ETH Zurich

26 PUBLICATIONS 483 CITATIONS

[SEE PROFILE](#)

Superconducting devices for radioastronomy; First steps in Chile: SNS-junction fabrication

V. Conte*, J. L. Giordano†§, J. Luzuriaga‡, J. Zárata‡ and H. Pastoriza‡

*Applied Sciences Ph.D. Program, Universidad de Talca, Chile

†Applied Sciences Department, Universidad de Talca, Chile

‡Comisión Nacional de Energía Atómica, Centro Atómico Bariloche, 8400-S.C. de Bariloche, Argentina

§Contact: giordano@utalca.cl, phone +56 75 201709

Abstract—We present results of the microfabrication of Josephson Junctions (JJs) of Superconductor-Normal-superconductor (SNS) type, as a first step in the acquisition of the know-how of superconducting devices applied to radioastronomy. A two-junction SQUID was built using a Nb/Al bilayer deposited on a Si wafer. The procedure needs only one mask and a single UV exposure (i.e., one photolithography step). We show the micrograph and the observed non linear characteristic I - V curve at 4K of the first device fabricated in the framework of ALMA Grant 31090010.

I. INTRODUCTION

Almost 50 years ago, using the tunnel quantum effect and the BCS theory Josephson predicted the tunneling of Cooper pairs between two superconductors (S) through an ~ 1 nm insulating barrier (I) [1]. This was the starting point of the development of Superconducting Tunneling Junctions (STJs) for sensitive superconducting quantum interference device (SQUID) magnetometers, detectors and mixers for astronomical applications.

The Atacama Large Millimeter Array (ALMA, 1995-2012) radio telescope is an array of 64 antennas of 12 m-diameter to observe the Universe from the Atacama desert (Chile) at 5 km altitude, where the sky is exceptionally dry and clear. This facility will be the world's most extensive superconducting receiver system with 10 bands in the 31.3 - 950 GHz ($= 9.6 - 0.3$ mm) range providing detailed images from galaxies, stars and planet formation and will be useful for testing cosmological models. Superconducting devices are essential for mm-submm radioastronomy, and measurements of most ALMA bands are only possible by the use of STJ-based detectors [2].

We present here the first experimental results of the ALMA Grants 31070019, 31080012 and the current 31090010, devoted to research and training on superconducting devices for astronomical applications, and also to develop the relevant know-how on Superconductivity in Chile, via Ph.D. theses focused on the new technologies used in radio telescopes. Additionally, this project intends to strengthen the scientific collaboration among local groups and research centers abroad, specifically Caltech/JPL (USA) and Centro Atómico Bariloche (CAB, Argentina).

II. THEORETICAL BACKGROUND

In 1962 Brian Josephson, then a twenty-two year old graduate student, made a remarkable prediction [1] that two superconductors separated by a thin insulating barrier should give rise to a spontaneous (zero voltage) DC current.

The lossless tunneling current was found to depend upon the difference between the phases of the condensate wave functions for the superconductors on each side of the barrier as

$$I(t) = I_c(T) \sin \phi(t) \quad (1)$$

where ϕ is the phase difference and $I_c(T)$ is the maximum current that can be driven through the junction without dissipation.

When a DC potential V_0 is present across the barrier, ϕ varies in time as:

$$\frac{d\phi}{dt} = 2eV_0/\hbar \quad (2)$$

A Josephson Junction can be described in terms of *weak links*. The weak link can be an insulating layer (SIS junction), as Josephson originally proposed, or a normal metal layer (SNS junction) made weakly superconductive by the so-called *proximity effect* (in which Cooper pairs from a superconducting metal diffuse into the normal metal).

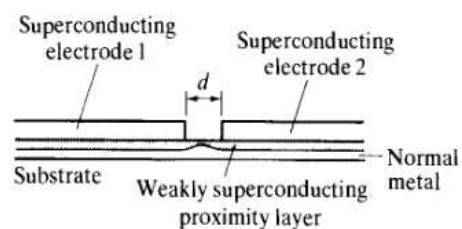

Fig. 1. Proximity effect SNS Josephson junction [3].

In the SNS junction, the normal metal coherence length ψ_n sets the length scale and I_c falls with the thickness d of the normal region as $e^{-\psi/d}$ [3].

We can consider a Josephson junction with a I - V characteristic given by (1) to be in parallel with a capacitor C and a shunt resistance R . If we connect this junction in series with a current source as is shown in Fig. 2, we can analyze the system using the so called resistively and capacitively shunted junction (RSJC Model) where R is the resistance in

the finite voltage regime, while C reflects the capacitance of the electrodes.

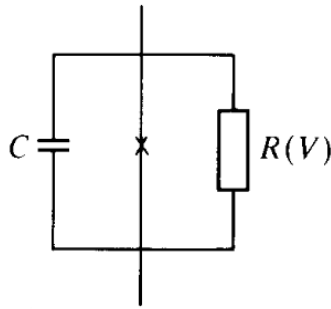

Fig. 2. Equivalent circuit of a Josephson junction by the RSJC model [3].

Within the RSJC model, the time dependence of the phase ϕ is given by the voltage resulting from the parallel distribution of the bias current I in the 3 channels of Fig. 2.

$$I = I_c \sin \phi + V/R + CdV/dt \quad (3)$$

Using (2) and (3) and for a small capacitance C the system is overdamped. The resulting (scaled) I - V dependence is shown in Fig. 3.

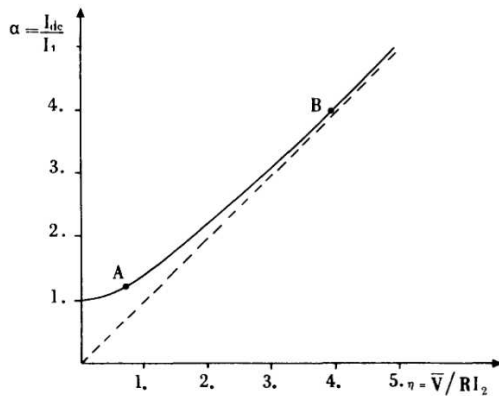

Fig. 3. Overdamped characteristic curve [4].

III. SAMPLES FABRICATION

We have built proximity effect SNS junctions, using the technique of UV Photolithography to define a circuit on a thin film bilayer of aluminium (Al) and niobium (Nb) using a Cr metalized glass plate as photo mask, containing the pattern. The bilayer was deposited by magnetron sputtering on a single crystal Si wafer.

The samples were made at the Centro Atómico Bariloche by the following microfabrication process:

- 1) Metallic Layers Deposition: After reaching a pressure of 10^{-7} Torr, the Ar plasma is turned-on at 50 mTorr. First an Al thin film is grown on the Si substrate by RF magnetron sputtering. Then without breaking the vacuum, a Nb thin film is grown on top of the Al by DC magnetron sputtering. Deposition ratios were 40 nm/min

for Al, using 50 W of RF power and 80 nm/min for Nb using 100 W of DC power, both at pressures of 10 mTorr.

- 2) Resist Application: Spin-coating was used to form a thin layer of UV-sensitive photo resin (positive Microposit 1400-31). This was soft-baked at 90 °C for 120 seconds. The sample was exposed for 5 seconds to UV light through the photo mask. Then we removed the more soluble (UV-exposed) regions by using microposit developer, and after this the sample was hard-baked at 120 °C for 120 seconds.
- 3) Dry Plasma Etching: The metallic layers not covered by the resist are removed using Reactive Ion Etching (RIE) with SF₆ gas.
- 4) Stripping: Removal of resist with acetone.
- 5) Electrical contacts: Four-point contacts were made using epoxy with silver particles (Epotek) and gold wires.

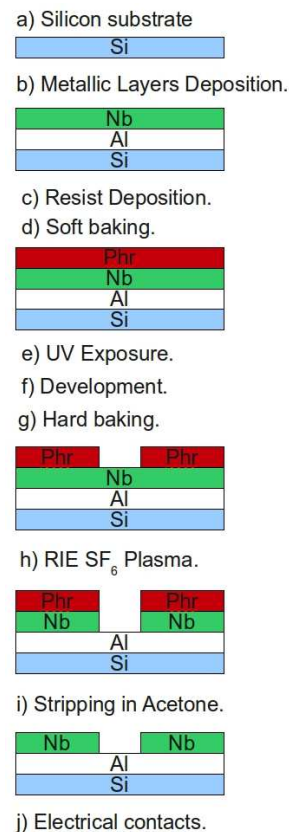

Fig. 4. Fabrication process.

IV. EXPERIMENTAL WORK

We characterized the metallic deposition rate of the sputtering machine by using an UV-Lithography-based technique using the following steps: 1) Photolithography with positive photo resin over Si wafer. 2) Sputtering. 3) Lit-Off with acetone. 4) Measurement in optical profiler (OP).

To measure the resin thickness with the OP, gold or silver were sputtered on the surface.

The etching rate was measured by producing a step in the film by attacking an uncovered region with RIE, using SF₆

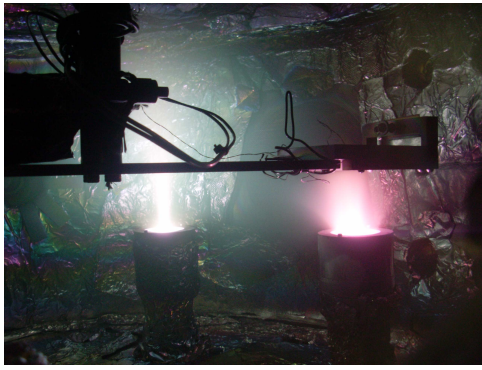

Fig. 5. Photograph of the bi-layer fabrication with niobium (left) and aluminum (right) sources by magnetron DC/RF sputtering under argon atmosphere.

reactive gas. The electrical power used was 300 W at 10 mTorr (for Plasma generation) and 70 W (bias power for acceleration against the sample). The step height was measured using the OP.

The T_c of the Nb/Al bi-layer is determined from the magnetization vs temperature curve measured with a SQUID magnetometer in Zero Field Cooling (ZFC) and Field Cooling (FC) temperature sweeps (Fig. 6).

The patterned sample (Fig. 8) was mounted in a cryostat (Fig. 7) and the I - V characteristic was measured at 4 K in zero applied magnetic field (Fig.9).

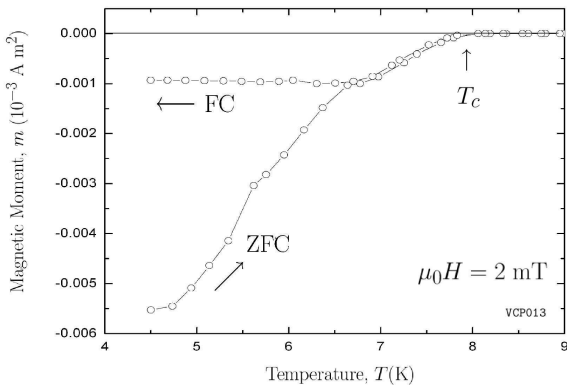

Fig. 6. Magnetization $m(T)$ vs temperature of the Nb (200 nm)/Al (200 nm) bi-layer control sample. The measured T_c is 7.8 K

V. CONCLUSIONS

The result $T_c \sim 8$ K shows the acceptable quality of the Nb (S) layer. According to the Resistively Shunted Junction (RSJ) model [4], [5] the characteristic curve qualitatively corresponds to a junction with negligible capacitance. Quantum interference experiments applying magnetic field on the double SNS-junction loop are being prepared. We are beginning to build SNS junctions, as a starting point in the study of superconducting devices for radioastronomy. The construction and testing of new SNS and SIS junctions in a complete detection system is being planned.

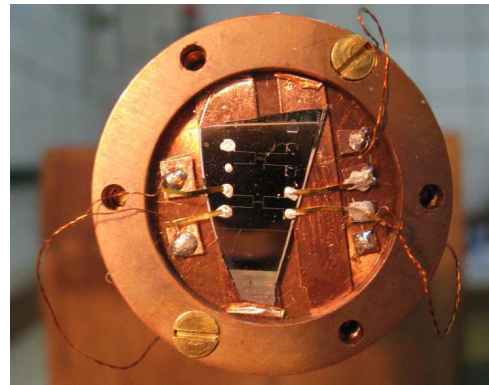

Fig. 7. Sample mounted on the cold finger.

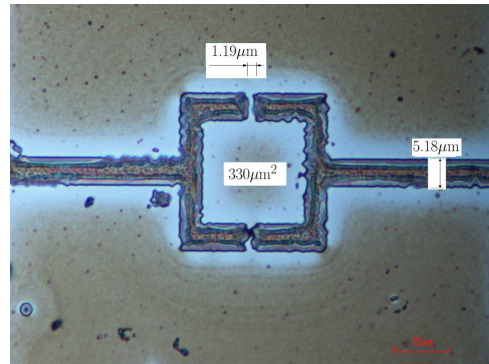

Fig. 8. Micrograph of the first sample. The patterned Nb layer can be seen. The two gaps form the SNS junctions, the Al layer below provides the normal metal path between the superconducting strips. This circuit forms a two slit SQUID.

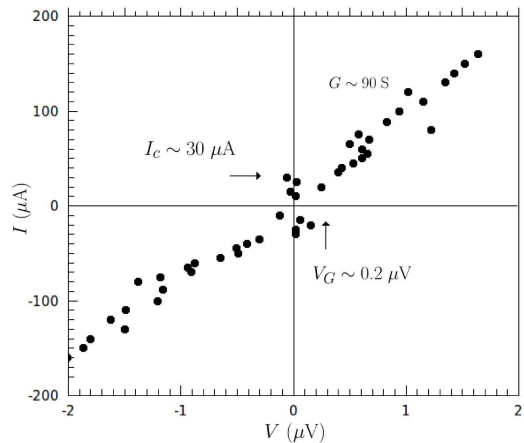

Fig. 9. I - V characteristic curve of the sample at 4K and zero magnetic field showing the damped characteristic as in Fig. 3 [4]

ACKNOWLEDGMENTS

The authors would like to thank ALMA Fund for the Development of Chilean Astronomy, Grants 31080012 and 31090010. We also thank Dr. Jonas Zmuidzinas (CALTECH and JPL at Pasadena, CA, USA) for his scientific support and stimulating discussions. University of Talca for partial support and VCs Ph.D. scholarship. VC also thanks to Gladys Nieva, Julio Guimpel and Ignacio Artola for technical assistance.

REFERENCES

- [1] Josephson B. D. "Possible new effects in superconducting tunneling" *Phys. Lett.* 1, 251, 1962 & Anderson P.W. and Rowell J. M. "Probable Observation of the Josephson Superconducting Tunneling Effect" *Phys. Rev. Lett.* 10, 230, 1963
- [2] Zmuidzinas J. and Harris P. L. "Superconducting Detectors and Mixers for Millimeter and Submillimeter Astrophysics" *Proceedings of the IEEE* 92 1597-1616, 2004
- [3] Tinkham M. *Introduction to Superconductivity* 2nd Ed. Dover, 1996
- [4] Barone A. and Paternò G. *Physics Applications of Josephson Effect* John Wiley & Sons, 1982
- [5] Van Duzer T. and Turner C. W. *Principles of Superconductive Devices and Circuits* 2nd ed. NJ: Prentice-Hall, 1999