

**CRYSTALLOGRAPHIC DATA****167. Potassium Uranyl Vanadate,  $KUO_2VO_4$** 

MARÍA J. de ABELEDO, MARÍA R. de BENYACAR, and ROBERTO POLJAK

Comisión Nacional de Energía Atómica, Buenos Aires, Argentina

POTASSIUM uranyl vanadate (synthetic anhydrous carnotite) was prepared by melting a mixture of ammonium uranate with twice the stoichiometric amount of potassium vanadate; the technique was fundamentally that

proposed by Canneri and Pestelli (1). After cooling, beautiful yellow plates up to 3 mm. long were obtained.

**CRYSTAL MORPHOLOGY**

To facilitate the comparison, the set-

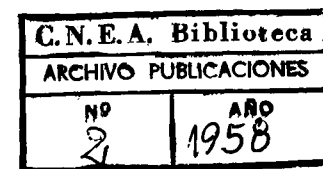

ting chosen by Sundberg and Sillén (5) has been conserved through the text, although the authors think it preferable to interchange axes *a* and *c*—that is, to adopt the setting used by Donnay and Donnay (2).

System and class. Monoclinic, prismatic (5).

Axial elements. *a*:*b*:*c* = 0.784:1:-1.24 [derived from unit cell dimensions (5)].

Table I. Partial Powder X-Ray Diffraction Patterns of Synthetic Anhydrous Carnotite

<i>hkl</i> ( <i>δ</i> )	<i>d</i> , A. (Calcd.) <sup>a</sup>	<i>d</i> , A. (Obsd.) <sup>b</sup>	<i>I</i> <sup>c</sup>	<i>hkl</i> ( <i>δ</i> )	<i>d</i> , A. (Calcd.) <sup>a</sup>	<i>d</i> , A. (Obsd.) <sup>b</sup>	<i>I</i> <sup>c</sup>
		6.32	VS	315	1.654		
		5.04/	VW	(016)	1.653		
		4.15	MW	333	1.649		
120	3.702	3.48	MW	402	1.643	1.646	MW
112	3.281			(224)	1.640		
200	3.196	3.19	S	035	1.640		
013	3.128			331	1.621		
113	3.103			(151)	1.621		
122	3.084	3.08	M	313	1.600		
202	3.060			400	1.598	1.603	M
(211)	3.060			152	1.577		
210	2.974			413	1.576	1.576	W
211	2.700			226	1.556		
031	2.689	2.69	W	422	1.530		
113	2.597	2.59	VW	404/	1.530	1.532	W
220	2.553			411	1.498	1.501	S
213	2.542	2.533	MW	340	1.496		
222	2.474			420	1.494		
(114)	2.465	2.464	VW	335	1.480	1.477	VW
032	2.451			126	1.480		
(202)	2.444					1.454	W
033	2.155			153	1.430	1.434	VW
(231)	2.132			415	1.416	1.422	VW
300	2.130	2.142	M	333	1.409		
(311)	2.124			154	1.408		
		2.064	VW	433	1.392	1.393	VW
115	2.021			324	1.381		
213	2.018	2.020	W			1.367	VW
140	1.996					1.343	VW
313	1.982	1.979	W			1.317	W
015	1.966			155	1.308		
042	1.941			413	1.307		
		1.939	MS			1.294	VW
311	1.935			513	1.280		
124	1.933			435	1.278	1.277	VW
233	1.933					1.264	VW
322	1.922			522	1.259		
320	1.902	1.900	M			1.249	VW
215	1.886					1.238	VW
302	1.810			(236)	1.224		
142	1.809	1.824	W	520	1.223	1.224	VW
312	1.770			(404)	1.223		
115	1.765	1.766	VW	028	1.210		
234	1.764			532	1.193		
240	1.754			256	1.184		
006	1.685			533	1.183		
135	1.670			362	1.176		
233	1.669	1.675	MW	452	1.175		
206	1.669			(118)	1.174		
				(451)	1.174		

<sup>a</sup> From values of  $10^4 \sin^2 \theta$  (*δ*).

<sup>b</sup> 100-mm. diameter powder camera,  $(CoK\alpha)\lambda = 1.7902$  A.

<sup>c</sup> Observed visually.

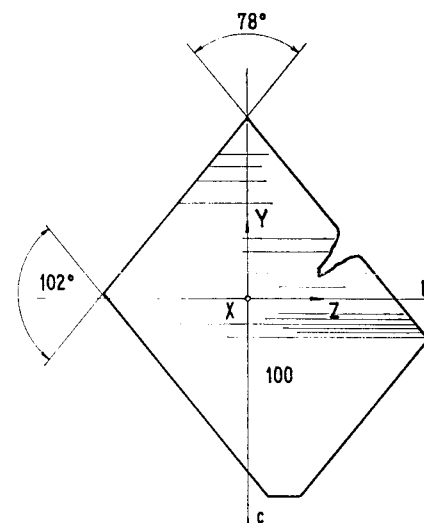

Figure 1. Orthographic projection of crystal of potassium uranyl vanadate

Habit. Rhomboidal plates flattened {100}, bounded by {011}. The smaller crystals appear less elongated (Figure 2). The thickness of several plates was determined both on the microscope and by measuring the shadow cast by the crystal after shadow-casting with aluminum (Figure 3). Values ranging from 25 to 70 microns were obtained. Many plates were about 30 microns thick.

Cleavage. {100} perfect; {001} prominent.

Interfacial angles.  $011 \wedge 0\bar{1}1 = 78^\circ$  (observed optically and measured on electron micrographs).

Beta angle.  $104.2^\circ$  (5).

**X-RAY AND ELECTRON DIFFRACTION DATA**

The structure of anhydrous potassium uranyl vanadate has been determined by Sundberg and Sillén (5) on crystals obtained by a technique somewhat dif-

ferent than that described by Canneri and Pestelli. They give the following values:

Space group.  $C_{2h}^2$

Values of cell dimensions given by Sundberg and Sillén are  $a = 6.590$  A.;  $b = 8.403$  A.;  $c = 10.430$  A.

Volume of Unit Cell. 560.0 A.

Formula units per cell. 4.

From single crystal photographs, Sundberg and Sillén conclude that "the diagonal axis coincides with the diagonal of the acute angles in the plate." Of

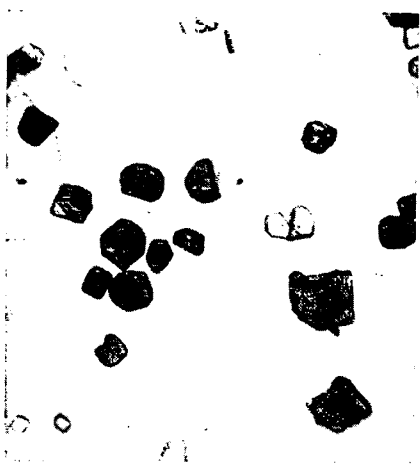

Figure 2. Crystals of potassium uranyl vanadate,  $K_2UO_2VO_4$



Figure 3. Crystals of potassium uranyl vanadate, shadowed with aluminum

Angle of shadowing,  $10^\circ$

the other two axes, one, which they denote by  $c$ , lies also in the plane of the plate; the third,  $a$ , is at an angle to it.

Rotation single crystal photographs indicate that in our crystals the diagonal axis lies in the plane of the plate and bisects the obtuse angle (Figure 1); another axis,  $c$ , lies also in the plane of the

plate, and the third one,  $a$ , is at an angle to it. These results were confirmed in patterns obtained by the precession method (6).

Electron diffraction photographs from single crystals were obtained in a three-stage Philips electron microscope; gold was used for calibration. Those Kikuchi patterns show that the 2 axes lying in the plane of the plate cut at an angle of  $90^\circ$ . The values obtained from measurements on the electron diffraction patterns are:  $b = 8.45$  A.;  $c = 10.43$  A.

Formula Weight. 424.12.

Density. 5.03 (x-ray); 5.02 (pycnometer).

#### OPTICAL PROPERTIES

Refractive Indices (5893 A.).  $\beta = 1.98 (\pm 0.02)$ ;  $\gamma = 2.10 (\pm 0.02)$   
 $\sqrt[3]{\alpha\beta\gamma}$  [calculated from measured density and specific refractive energies (4) using  $k = 0.340$  for  $V_2O_5$  as given by Jaffe (8)] 1.925;  $\alpha$ , calculated from  $\sqrt[3]{\alpha\beta\gamma} = 1.71$ .

Molecular Refraction (based on measured density). 40.0.

Optical Orientation.  $Z = b$ .  $X$  nearly vertical, makes an angle of  $3^\circ$  with the normal to the plate.

Optic Sign. Negative.

Optical Axial Angle (5893 A.).  $49^\circ$ .

Dispersion.  $r < v$ .

Color. Yellow. Pleochroism not observable.

#### ACKNOWLEDGMENT

The authors wish to acknowledge the help given by Edelmira Mortola with the work in the Fedorov stage, and by E. Tavora with the x-ray study by the precession method.

Table II. Comparison of Partial Powder X-Ray Diffraction Patterns of Synthetic and Natural Carnotite

Natural Carnotite (from Cerro Huemul-Mendoza- R. Arg.)		Synthetic Anhy- drous Carnotite	
$d$ , A.	$I$ (est.)	$d$ , A.	$I$ (est.)
6.45	10	6.32	VS
5.41	Barely vis.		
5.04	0.5	5.04	VW
4.17	5	4.15	MW
3.506	6	3.48	MW
3.222/	0.5		
3.211	7	3.19	S
3.135	6		
3.082	9	3.08	M
2.686	2	2.69	W
2.604	Barely vis.	2.59	VW
2.540	4	2.533	MW
2.463	Barely vis.	2.464	VW
2.360	Barely vis.		
2.150	8	2.142	M
2.095	Barely vis.	2.064	VW
2.050	Barely vis.		
2.021	5	2.020	W
1.992	3		
1.977	3	1.979	W
1.934	10	1.939	MS
1.901	3	1.900	M
1.822	2	1.824	W
1.777	2		
1.765	2	1.766	VW
1.734	0.5		
1.695	0.5	1.675	MW
1.669	10		
1.656	3	1.646	MW
1.607	3	1.603	M
1.594	3	1.576	W
1.569	2	1.532	W
1.540	2		
1.500	4	1.501	S
1.474	Barely vis.	1.477	VW
		1.454	W
1.449	4	1.434	VW
1.425	2	1.422	VW

#### LITERATURE CITED

- (1) Canneri, G., Pestelli, V., *Gazz. chim. ital.* 54, 641 (1924).
- (2) Donnay, G., Donnay, J. D. H., *Am. Mineralogist* 39, 323 (1954).
- (3) Jaffe, H. N., *Ibid.*, 41, 757 (1956).
- (4) Larsen, E. S., Berman, H., U. S. Geol. Survey, Bull. 848, 31 (1934).
- (5) Sundberg, I., Sillén, L. C., *Arkiv Kemi* 1, 337-51 (1949).
- (6) Tavora, E., Conselho Nacional de Pesquisas, Rio de Janeiro, personal communication.

CONTRIBUTIONS of crystallographic data for this section should be sent to W. C. McCrone, 500 East 33rd St., Chicago 16, Ill.