

Phase diagram and superconductive properties of splat-cooled $\text{Cu}_x\text{La}_{1-x}$

J. Favaron,* M. E. de la Cruz, P. Esquinazi, and F. de la Cruz

Centro Atómico Bariloche,[†] Instituto Balseiro,^{†*} 8400 San Carlos de Bariloche, Rio Negro, Argentina

(Received 23 August 1979)

The phase diagram of nonequilibrium, splat-cooled $\text{Cu}_x\text{La}_{1-x}$ is interpreted by means of superconductive-transition and x-ray measurements. At the eutectic composition the material is shown to be in a highly disordered state. Measurements of dc resistance and ac susceptibility show that there are two different critical fields at the disordered concentration although there is a unique critical temperature.

I. INTRODUCTION

The study of disordered metals is the subject of recent interest.¹ Some of these metals are superconducting but few of them remain in a highly disordered state at room temperature. The relation between the superconducting properties and the state of disorder is of theoretical and experimental importance for a better understanding of amorphous systems. Disorder has been shown to strongly affect the thermodynamic properties of the superconducting state of simple metals¹ but, on the other hand, the critical temperature of lanthanum alloys does not seem to be modified by the degree of disorder.²⁻⁴ Among these alloys the $\text{Au}_x\text{La}_{1-x}$ system has been studied most extensively.²⁻⁶ High-disorder bulk samples of this alloy can be obtained at room temperature by using splat-cooling techniques.²⁻⁵ Amorphous samples have also been obtained by vapor deposition at 4 K.⁶ It has been shown^{3,6} that to maintain the disorder at room temperature the Au concentration has to be very close to the eutectic composition. A good indicator of the existence of a single disordered phase is the temperature width of the superconducting transition. According to Ref. 3, when the gold concentration does not correspond to the eutectic composition, the x-ray diagram indicates the presence of a crystalline phase that, eventually, coexists with the amorphous one. It is interesting, however, to note that the appearance of a crystalline phase on either side of the eutectic composition is accompanied by a dramatic increase in the superconducting transition width³ (more than 1 K) as measured by the dc electrical resistance. However, since the critical temperatures of the amorphous and crystalline phases can be well separated, one would not expect a single, broad transition but either a single transition at the highest critical temperature or, if the phase of highest critical temperature does not short circuit the entire sample, two transitions.

Experiments⁶ on alloys condensed from the vapor at low temperatures show that the transition width does not depend on Au concentration and, since in

this case there is always a single amorphous phase, the increase in the transition width in splat-cooled samples must be related to the appearance of the crystalline phase.

Because of the experimental convenience of being able to fabricate bulk disordered samples which are stable at room temperature we considered it of interest to study a similar alloy⁷ ($\text{Cu}_x\text{La}_{1-x}$) which can be prepared by splat-cooling methods. Because the superconductive behavior of metals is usually characterized in terms of their superconductive transitions, we have determined the phase diagram of the system from this point of view and measured the superconductive phase boundaries and transition widths.

The superconducting phase boundary was determined by measuring the dc electrical resistance and the ac susceptibility as a function of temperature and magnetic field. The study of the phase diagram was supported by x-ray analysis of the samples.

II. EXPERIMENTAL PROCEDURE

Samples were prepared from two different batches of lanthanum (99.6% and 99.99% nominal purities) and oxygen-free high-conductivity (OFHC) copper. Alloy samples of about 1 g were obtained by repeated melting and mixing of the pure components in an argon-filled arc furnace. These ingots were then cut in several pieces of about 0.15 g and the resulting pellets were then melted in the arc furnace and splat cooled on a water-cooled copper surface. The technique is a modification of one introduced by Matthias *et al.*⁸ and used by Luo⁹ and Donkersloot and Van Vucht.¹⁰ We project the melted metal onto the cold copper surface by means of a shock wave produced by the rupture of a Mylar diaphragm under argon pressure. The samples obtained are irregular foils of 2 to 3 cm² with a more or less uniform thickness of 20 to 60 μm . The samples were x-ray analyzed with a diffractometer using $\text{Cu } K\alpha$ radiation.

The critical temperature at zero field was determined as a function of Cu concentration by measuring the electrical resistance of the sample, using the

standard four-probe technique. The temperature could be continuously controlled from 1.5 to 15 K. When it was necessary to apply a magnetic field the measurements were done in another cryostat in which the sample was immersed in liquid helium. The magnetic field was supplied by an iron magnet that could be rotated to change the angle between the sample surface and the field. In this cryostat the dc resistance and ac measurements were made simultaneously. The ac susceptibility was measured by means of a mutual-inductance bridge.

III. EXPERIMENTAL RESULTS

A. Structure analysis

Figure 1 shows the equilibrium diagram of the $\text{Cu}_x\text{La}_{1-x}$ system⁷ and the nonequilibrium one obtained by x-ray analysis of the splat-cooled samples. The splat-cooled, pure lanthanum was stabilized in the high temperature fcc phase, some times admixed with a small amount of the lower-temperature hcp phase. The lattice parameter calculated from the diffractometer data agrees with results¹¹ given in the literature.

The x-ray diagrams were found to be free of crystalline peaks only in a very narrow range of concentration of copper, near $x = 0.30$.

This corresponds to the equilibrium eutectic concentration⁷ and the x-ray pattern was typical for an amorphous substance: A broad intensity maximum at $2\theta \sim 31^\circ$ and two or more maxima of lower intensities at higher angles.

Any departure from $x = 0.30$ produces a mixture of two phases indicated by the presence of crystalline sharp peaks superimposed on the broad amorphous

maximum. The relative intensities of the broad maximum compared to the height of the sharp peaks give an idea of the proportion of the coexisting phases.

When x is decreased the proportion of the fcc crystalline phase is observed to increase until for x less than 0.10 the amorphous phase is scarcely observed.

The resolution of our diffractometer does not allow us to detect variations of the lattice parameter as a function of copper concentration. As a consequence we cannot distinguish between a segregated fcc pure lanthanum phase from a nonequilibrium CuLa solid solution. In Fig. 1(b) we identify this nonequilibrium region as a mixture of fcc β' phase and the amorphous A phase.

For $0.30 < x < 0.40$ there is a crystalline phase mixed with the amorphous one. The crystalline phase was identified as the equilibrium stoichiometric CuLa compound. When $x > 0.40$ the amorphous phase appears no more in the x-ray diagram: The sample is composed of a mixture of the stoichiometric compounds CuLa and Cu_2La in their equilibrium structures. It is interesting to note that in the splat-cooled phase diagram the Cu_2La compound starts to appear at $x = 0.40$, before expected in the equilibrium diagram. The splat-cooling technique is too rapid to allow for a complete peritectic decomposition of the Cu_2La formed in the cooling process. When samples of the single amorphous phase ($x = 0.30$) are examined by electron microscopy they appear to be made of small crystallites of about 20-Å diameter, suggesting a microcrystalline structure rather than a truly amorphous one. This 20-Å diameter coincides with the one obtained from the Scherrer formula applied to the broad peak of the x-ray patterns.

B. Superconductive transitions

Typical superconductive transitions as measured with the dc electrical resistance, for different atomic copper concentrations are shown in Fig. 2. These curves have to be taken as representative since their detailed shape varies for samples of the same copper concentration as shown in the figure. For all pure La samples 80% of the superconductive transition occurs within 150 mK. When copper is added the transition broadens, always starting near 6 K and showing long tails at lower temperatures. When the concentration of copper is close to 0.25 the transitions are quite broad ($\Delta T \sim 2$ K) and sharp steps can be observed near 4 K or below.

Homogeneous disordered samples ($x = 0.30$) have a critical temperature of 3.8 K and a transition width of 50 mK as seen in Fig. 2. In the same figure the results for a nonhomogeneous sample of the same concentration are shown.

The transitions are observed to start at 5.6 K when $x > 0.30$. If the copper concentration does not

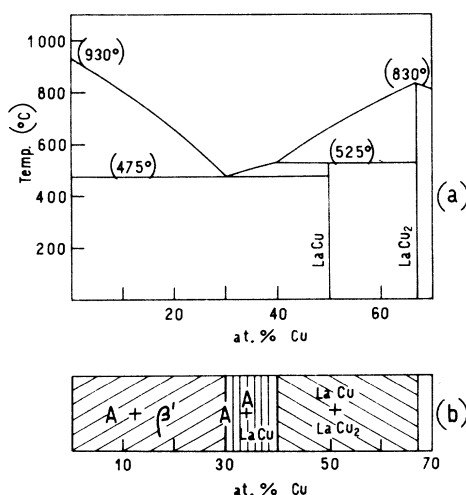

FIG. 1. (a) Constitutional phase diagram of the Cu-La system (Ref. 7). (b) Nonequilibrium diagram obtained by x-ray analysis of the splat-cooled samples of Cu-La.

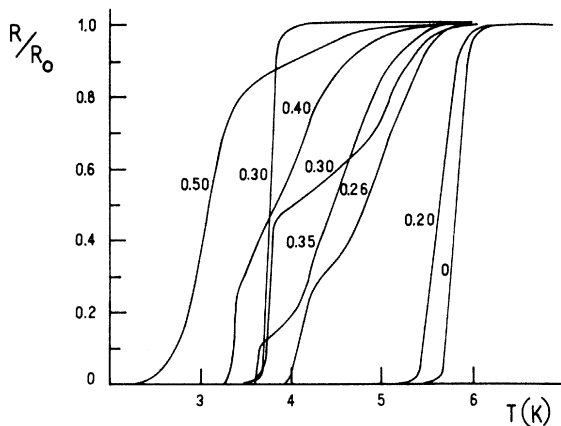

FIG. 2. Resistivity ratio as a function of temperature for $\text{Cu}_x\text{La}_{1-x}$ sput-cooled samples. The resistance is normalized by the residual one, R_0 , for each sample.

exceed 0.40 the transitions show steps below 3.8 K. For $0.40 < x < 0.55$ the steps disappear, the transitions are very broad and practically concentration independent. Figure 3 shows the total transition widths as a function of copper concentration.

Direct-current measurements of the superconducting transition as a function of magnetic field are shown in Fig. 4 for a homogeneous disordered sample with the field perpendicular to the sample surface. The superconducting transitions of the 30% alloy samples were also measured using the ac susceptibility technique. Figure 5 shows the superconducting transition at zero magnetic field as measured by both techniques. It is interesting to note that the ac susceptibility starts to detect superconductivity when the dc resistance indicates practically zero resistance. When a magnetic field is applied a similar behavior is observed and the critical field measured by the ac technique coincides with that field at which the dc resistance is about 1% of the total residual resistance.

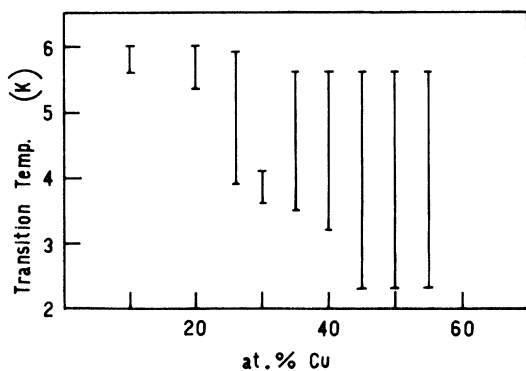

FIG. 3. Superconductive transition temperature as a function of alloy composition. Vertical bars indicate the total transition width (100% of the superconductive transition).

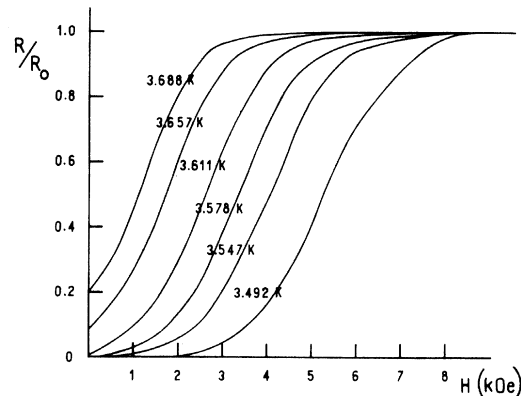

FIG. 4. Resistivity ratio as a function of magnetic field and temperature for a disordered $\text{Cu}_{30}\text{La}_{70}$ sample.

To plot a superconducting diagram we have used two different definitions of the critical field: H_{c2} is the value of the magnetic field for which the dc resistance is 50% of the normal state value, and $H'_{c2}(T)$ is defined as the field at which superconductivity starts to be detected by the ac susceptibility. Figure 6 shows the data for both definitions for the same disordered sample. Using the definition $H_{c2} = \alpha(T - T_{c2})$ it was found that α for $H'_{c2}(T)$ is about 30% lower than the value obtained from $H_{c2}(T)$ although the critical temperatures differ at most by 3%. These results are characteristic of all our disordered samples and are shown in Table I for three different ones. The ratio of the sample resistance at room temperature to the residual resistance is less than 2 for the homogeneously disordered samples at 30% atomic copper concentration. All other concentrations have greater resistivity ratios.

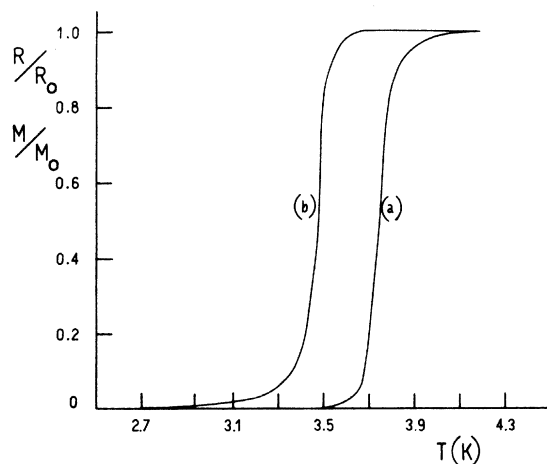

FIG. 5. (a) Resistivity ratio as a function of temperature for a $\text{Cu}_{30}\text{La}_{70}$ sput-cooled sample. (b) Normalized amplitude of the ac susceptibility as a function of temperature for the same $\text{Cu}_{30}\text{La}_{70}$ sample.

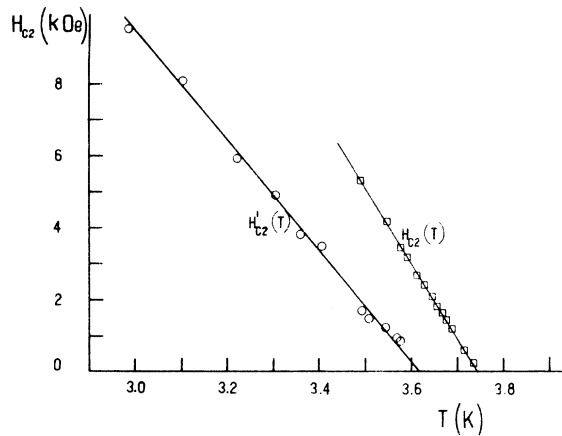

FIG. 6. Upper critical field as a function of temperature for a splat-cooled $\text{Cu}_{30}\text{La}_{70}$ sample. $H_{c2}(T)$ represents the results obtained by dc electrical resistivity measurements and $H'_{c2}(T)$ those obtained by ac susceptibility measurements. The solid line is a mean square fit of the experimental data.

IV. DISCUSSION

A. Superconductive transition as a function of copper concentration

When the transition width of these samples, shown in Fig. 2, is compared with those of the $\text{Au}_x\text{La}_{1-x}$ system of Ref. 3, some differences are immediately noticed. We see that for the lanthanum-rich region the transitions of the $\text{Cu}_x\text{La}_{1-x}$ system are narrower than those of the $\text{Au}_x\text{La}_{1-x}$ system. This result is related to the fact that our samples were always stabilized in the fcc phase with very little if any, of the hcp admixed. From this result we might conclude that our splat-cooling technique is more efficient than the one used by Johnson *et al.*³ On the other hand our results for the disordered phase seem to indicate the contrary. In our alloy we were only able to get a pure disordered phase at the eutectic concentration; in Ref. 3 it is reported that the disordered state for $\text{Au}_x\text{La}_{1-x}$ is obtained in a wider range of Au concentration (within 10% of the eutectic point). Whether this difference can be attributed to intrinsic properties of the equilibrium phase diagrams is not known.

TABLE I. Values of dH_{c2}/dT and T_{c2} as defined in the text, for three different samples of $\text{Cu}_{30}\text{La}_{70}$.

$\frac{dH_{c2}}{dT} \left(\frac{\text{kOe}}{\text{K}} \right)$	$T_{c2}(\text{K})$	$\frac{dH'_{c2}}{dT} \left(\frac{\text{kOe}}{\text{K}} \right)$	$T'_{c2}(\text{K})$
19.6	3.75	15.3	3.62
20.5	3.815	14.2	3.75
19.5	3.77	14.28	3.71

When copper is added to pure lanthanum an increase in the superconducting transition width is observed (see Figs. 2 and 3). When $x \sim 0.25$ the transition suddenly broadens by a factor larger than two and a sharp step is obtained at a temperature somewhat higher than the critical temperature of the eutectic concentration. Although an increase in the copper solubility due to the rapid quenching cannot be ruled out, our resistivity results show that a certain proportion of segregated pure fcc lanthanum ($T_c = 6 \text{ K}$) has to be present.

This fact is evident even for the 26-at. % Cu sample where it is quite clear that the transition begins at 6 K. It seems reasonable to suppose that these non-equilibrium alloys are composed of small regions of different sizes of nearly pure fcc lanthanum surrounded by a disordered phase with a copper concentration close to 0.30. The transition broadening in this picture would be due to the proximity effect of the normal disordered region on the crystalline domains. The step in the transition would occur when there is not enough crystalline superconducting material to short circuit the entire sample. As a matter of fact, the x-ray analysis of the 26-at. % copper sample showed that the amount of crystalline phase is much smaller than the disordered one. This explanation is similar to the one used by Harris¹² to explain the superconducting transitions in his system.

B. Features of the superconductive transitions as a function of magnetic field

It is shown in Fig. 6 and Table I that the results from the dc and ac measurements give rise to two different slopes of the critical field and, approximately, a single critical temperature. Although the critical field for these disordered foils was angle independent, showing the absence of surface superconductivity, it is reasonable to assume that this material is a type-II superconductor. Since the disordered samples have a well defined critical temperature we conclude that there is a uniform superconducting attractive pairing interaction throughout the material. On the other hand if we extend the known properties of crystalline type-II superconductors to highly disordered systems¹ we conclude from the two different slopes of the critical field that, in the sample, the electron mean free path is not uniform. Since the ac technique is more sensitive to the average resistivity than the dc method we conclude that most of the sample has the longer mean free path (mfp) (lower H_{c2}). As the electronic mfp is usually obtained from the dc measurements we do not consider it meaningful to calculate the superconducting parameters until a better understanding of these results is possible. It is interesting to note that values of dH_{c2}/dT obtained from the dc measurements are quite similar to those obtained for the $\text{Au}_x\text{La}_{1-x}$ system.³ We do not know

whether this result is related to the sample preparation method or is an intrinsic property of the system. We are undertaking experiments to clarify this point.

ACKNOWLEDGMENTS

It is a pleasure to thank Mr. C. Lovey for electronic microscopy measurements and Dr. B. Gregory for

careful reading of the manuscript. The skillful assistance of the technicians of the Low Temperature Laboratory, particularly Mr. H. Tutzauer, is also gratefully acknowledged. One of the authors (P.E.) wants to acknowledge the financial support by the Instituto Balseiro. This work was partly supported by the OAS through the Multinational Program in Physics and the NSF Grant No. GF 38710.

*Programme de "Cooperation Scientifique et Technique" between the French and Argentine governments.

† Comisión Nacional de Energía Atómica.

‡ Universidad Nacional de Cuyo.

¹See for example, G. Bergmann, *Phys. Rep.* **27C**, 159 (1976).

²K. Agyeman, R. Müller, and C. C. Tsuei, *Phys. Rev. B* **19**, 193 (1978).

³W. L. Johnson, S. J. Poon, and P. Duwez, *Phys. Rev. B* **11**, 150 (1975).

⁴G. Fasol, J. S. Schilling, C. C. Tsuei, and F. Zimmer, *J. Phys. F* **8**, L257 (1978).

⁵W. H. Shull and D. G. Naugle, *Phys. Rev. Lett.* **39**, 1580 (1977).

⁶J. S. Manning and C. V. Briscoe, *Phys. Rev. B* **18**, 1177 (1978).

⁷S. Cirafici and A. Palenzona, *J. Less Common Met.* **53**, 199 (1977).

⁸B. T. Matthias *et al.*, *Phys. Rev.* **139**, A1501 (1965).

⁹H. J. Luo, *J. Less Common Met.* **15**, 299 (1968).

¹⁰H. C. Donkersloot and J. H. N. Van Vucht, *J. Less Common Met.* **20**, 83 (1970).

¹¹J. Donohue, *The Structure of the Elements* (Wiley, New York, 1974).

¹²S. C. Harris, *Proc. R. Soc. London Ser. A* **350**, 267 (1976).