



(11) (A) No. **1 189 361**

(45) ISSUED 850625

(52) CLASS 78-40

(51) INT. CL. B23K 5/14³

(19) (CA) **CANADIAN PATENT** (12)

(54) Equipment for Welding End Caps to Nuclear Fuel Rods

(72) Cirimello, Roberto O.;
Tamanini, Hector F.;
Martinez, Roberto L.;
Balzaretti, Daniel E.;
Carella, Eduardo,
Argentina

(73) Granted to Invap S.E.
Argentina

(21) APPLICATION No. 406,412

(22) FILED 820630

(30) PRIORITY DATE Argentina (285,971) 810702

No. OF CLAIMS 3

Canada

ABSTRACT OF THE DISCLOSURE

Equipment for the welding of end caps to nuclear fuel rods, having only one chamber with two enclosures for welding arranged so as to be able to weld simultaneously opposite ends in rods placed in the magazine and displayed at 180°. The vacuum process of the main chamber takes place simultaneously with the welding of the first end caps to the rods and, in which the fill in process with inert gas takes place before welding the second end caps to the mentioned rods.

The present invention relates to a new equipment for resistance welding end caps to nuclear fuel. Due to its special design, high reliability, high efficiency and automatic operation, it represents
5 a genuine technological improvement in the field of fuel manufacture for nuclear reactors, in particular those of the CANDU type or those of short length.

Nuclear fuel rods manufacture resides in the introduction of the fuel in the form of cylindrical
10 pellets, within thin-walled metallic clads of special alloys of which the most important characteristic is the low parasitic neutron absorption.

Fuel rods are sealed at their ends by end caps of similar material which must be carefully welded to the
15 clads after a vacuum process followed by their being filled with an inert gas. Equipment for the resistance welding of end caps to fuel rod clads presently exists. In these equipments, the different operations are performed step by step in a complicated way because the clads,
20 carried on a flat tray or on a cylindrical magazine, are welded at one of their ends into a chamber, are then removed by rotating the tray or magazine 180°; are afterwards again introduced into the chamber, are subjected to a vacuum process and, finally, are filled with inert gas
25 and their other end is welded. The inert gas atmosphere is sometimes obtained by passing gas throughout the tube before welding both end caps. There are other processes in which the clads pass along three chambers: the opposite end caps of the clads are welded in two of them
30 and there is an intermediate operation for vacuuming and filling-in with inert gas.

As a consequence of this type of operation, there is too much rod circulation, low production and high costs.

The present invention overcomes these diffi-
35 culties in an advantageous way because it performs all



operations on the rods within only one chamber, having all necessary devices for welding both caps to their ends, vacuum process and fill-in with inert gas, without changing the orientation of the parts and taking advantages offered by a circular run of the rods within only one chamber.

To succeed in this advantageous way of operating, the fuel rods are placed on a rotating magazine, out of the equipment and before their introduction into the chamber. This is performed with the help of a carrier or any other adequate device.

So, one of the objects of the present invention is to provide an equipment for the welding of end caps to nuclear fuel rods, having only one chamber with two enclosures for welding arranged in such a way as to be able to weld simultaneously opposite ends in rods placed on the magazine and displayed in 180°.

It is also an object of the present invention to provide an equipment for welding end caps to nuclear fuel rods in which the vacuum process of the main chamber takes place simultaneously with the welding of the first end caps to the rods and, in which fill-in with inert gas takes place before welding the second end caps to the mentioned rods.

Accordingly, the invention as herein broadly claimed is an equipment for welding end caps to nuclear fuel rods, comprising: means defining a main chamber having two vertical and parallel faces and containing a rod supporting magazine having an axis perpendicular to the mentioned vertical faces; wherein said magazine is formed by a cylindrical drum having bases which protrude as crowns of the drum cylindrical surface; peripherically, said drum presents two cylindrical surfaces which contact by friction the corresponding seats of both rod butts, as they are placed between protrusions, as crowns of said

bases, and the said mean rod butt rings for initial
positioning; a quantity of $2n$ guide-rods rigidly linked
to the crown-like protrusions of the bases which axis are
regularly arranged on a cylindrical surface as generators;
5 several $2n$ rod-supports, each of which is linked in an
axially sliding way to each of the named guide-rods, and
present a contention elastic mean that can be linked to a
discontinuous part of the cylindrical drum outer
surface, at the same distance from the bases; each of
10 these rods supports present two elastic clamps oriented
in a divergent radial way with respect to the cylindrical
drum axis, each of these rod-bearers being able to support
each of several $2n$ rods placed separately between the rod
butt rings; each rod butt ring presents on one side, a
15 positioning butt to avoid the corresponding rod butt ring
from being dragged by the cylindrical drum turn, and on
the other side two slots spread 180° among them, each one
can, while the rod butt end is in position, let one from
the several rods pass when the corresponding rod bearer
20 displaces over the corresponding guide-rod; the
cylindrical drum presents, axially, a dragging shaft,
the main chamber presents a centering axis linked to one
of its vertical faces, and a tailstock linked to its
other vertical face; the centering axis and the tailstock
25 lined up with the magazine axis can be linked to the
dragging shaft ends of the cylindrical drum due to the
movements of a pneumatic cylinder that is out of the main
chamber; the centering axis is linked to an indexing
plate that make the magazine turn by angular steps of
30 $180^\circ/n$; the main chamber presents an opening enabling the
magazine pass and is linked to a door having sealed
devices; two welding enclosures respectively abutted to
the two vertical faces and communicated with the main
chamber through two first holes lined up with the two
35 slots of the magazine rod butt rings; two pneumatic

cylinders for displacing rods which are abutted to the two vertical faces and present two stems which penetrate into the main chamber through two second holes lined up with the slots of the magazine rod butt rings and placed in vertical faces opposite to the corresponding first holes; these stems present rod dragging clamps at both ends; the welding chambers have welding devices and end caps feeding devices; the main chamber has two positioning pneumatic cylinders which stems can link themselves to both positioning butts of the magazine rod butt rings; the main chamber communicates, through the corresponding ducts, with an inert gas container, with a vacuum pump and with the environmental air through respective valves.

In order to specify the advantages so briefly commented, to which the users and specialists will be able to add others, and to help to understand the constructive, constitutive and operational characteristics, there follows a description of a preferred embodiment. It is illustrated schematically and without a given scale in the enclosed figures of drawing and it must be paid attention to the fact that, on account of being a preferred embodiment, it must not be given a restrictive or exclusive character with respect to the scope of protection of the present invention but be regarded as a simple intention of explaining or illustrating the basic conception on which it is based. In the drawing:

Fig. 1 shows, in perspective, the equipment which is the object of the present invention, with the magazine placed on the main chamber, in operational condition with its accessories.

Fig. 2 shows, in perspective, the main chamber with the magazine placed in such a way as to begin the operative cycle, from a vertical cut along the magazine axis.

Fig. 3 shows, in perspective, the main chamber with the magazine from a vertical cut along the axis of the second welding enclosure, during an end cap welding process.

5 In all figures, the same numerals refer to the same structural part.

Referring to Figure 1, there is shown a main chamber 1 without door (not illustrated) showing a magazine 2 within it, in operative position and loaded with tubes 3. From the main chamber, two pneumatic cylinders 4 protrude and they are used for displacing the tubes (due to the drawing perspective, only one cylinder can be seen).

10 Welding enclosures 5 and 5' where the caps are welded to the opposite ends of the tubes are also seen. A magazine turning device is indicated by reference numeral 6.

15 Also shown in Fig. 1 is a cart 7 for carrying the magazine, a general control panel 8, two vacuum pumps 9, two control boards for each welding enclosure and, shown in dotted lines for not being visible through the frame 11, are transformers 12 used during the projection welding process.

20 Reference numeral 13 points out the welding enclosure 5' fuse feeder which can be seen in a cut of the figure in such a way as to be able to see the location of pneumatic clamp 14 for clads, a cap leading head 15, an electromagnet 16 and a transducer 17.

25 Reference numeral 18 indicates a pair of inert gas containers and related means.

30 In Fig. 2, besides those references already mentioned with respect to Fig. 1, there are shown the main elements that form part of rotation device 6: a centering axis 19, which fits in with a dragging shaft 20 of magazine 2 and contacts at its other end the

tailstock 21 that is operated by cylinder 44; a bearing box 22, an indexing mechanism 23 coupled to the centering axis by means of a cube 24.

5 In the higher part of chamber 1 are placed the positioning pneumatic cylinders 25 (in order to present things clearly they have not been included either in Fig. 1 or in Fig. 3). Their rods end in forks 26 that can grasp two positioning butts 27, each of them fastened to a rod butt ring 28 which has a frictional crown-like seat over the cylindrical surface of a protrusion 29 of each base 30 of magazine 2.

10
15 Between rings 28 and protrusions 29, there are devices for the initial positioning of magazine 31 which are formed by little balls that are fit-in by means of a contention spring.

20 In relation to these protrusions 29, there are several 2n leading rods 32 for displacing the same quantity of rod supports 33 arranged as generators of a cylindrical surface. The rod supports 33 have, at their ends, two elastic clamps 34 which hold the tubes 3. These clamps are linked among them by means of an elastic strip 35 that as holding means can be clasped with a butt device formed by a hoop 36 placed over the external cylindrical surface of the drum 37 of magazine 2.

25 It must be pointed out that in one of the welding enclosures, 5' in Fig. 1, the axis thereof corresponds to line 38', Fig. 3.

Finally, reference numeral 39 shows guides for displacing and positioning magazine 2.

30 With respect to Fig. 3, besides those reference numerals already described in Figs. 1 and 2, there can be seen a rod guiding bushing 40 that defines, in its central part, a hole for passing rods 3 within the main chamber 1 and the welding enclosure 5.

35

Reference 41 indicates the slot for passing rods 3 opened in rings 28. Additional slots that cannot be seen in the figure, are opened at 180° from visible ones.

In this figure, it can be seen the rod 42 of cylinder 4 that has a rod dragging clamp 43 at its end.

In operation, magazine 2 already assembled with the 2n rods 3 to be welded, with bolts 27 pre-placed and with the initial positioning devices 31 clasped, is loaded on transporting cart 7 within the main chamber 1, led by guides 39 till its work position where tailstock 21 operated by cylinder 44 and insert point 19 can control the dragging shaft 20 of magazine 2. At that time, the cart 7 is withdrawn and the door of the main chamber 1 (not shown) is locked, giving it a watertight condition.

Starting from this situation, there begins an ordered series of operations controlled by panel 8 in an automatic way.

First of all, pneumatic cylinders 25 operate forks 26 to catch butts 27 and fasten butt rings 28 in such a way that slots 41 remain facing the welding enclosures 38 and 38' axis; simultaneously, vacuum process begins by operation of one of the two pumps 9 illustrated in Fig. 1.

During the vacuum operation and later fill-in process with inert gas, one of the end caps of the rods is welded to n rods within enclosure 5 taken from one half of the magazine, and the same quantity of rods from the other half undergo the same process within enclosure 5'. The second end caps of each rod are welded without interrupting the sequence within the inert gas atmosphere.

In this way, delays produced by emptying and filling of the main chamber 1, previous to welding operations, are abolished.

The welding of one cap to one end of the rod begins by operating stem 42 of cylinder 4. This one, by means of clamp 43 introduces the rod into the welding enclosure 5.

5 This clamp 43 always grasps the rod at one end of the clad having or not a cap welded to this end.

This stem 42 goes on advancing, defeating the elastic strip 35, this last gets rid of the hoop 36 and introduces the rod partially within the welding chamber 5.

10 Within chamber 5 the welding of the cap to the respective end of the rod is electrically performed, without material contribution, in a conventional way automatically controlled by one of the control boards 10.

15 Once the welding has taken place, stem 42 protracts, taking the bar again to its original position.

20 Simultaneously with the above described operations corresponding to welding chamber 5, similar operations on the opposite end of a rod placed on the magazine in a diametrically opposed position are performed within chamber 5'.

Both welding enclosures 5 and 5' present automatically controlled end cap feeders 13.

25 When the previously described operation finishes, the control panel 8 causes the indexing mechanism 23 to turn dragging the centering axis 19 throughout cube 24. This causes the magazine 2 to turn to welding position for the next rod in both enclosures 5 and 5', being the angular pass of $180^\circ/n$.

30 Once the welding of all rods with their two end caps has finished, chamber 1 is taken again to atmospheric pressure, the positioning cylinders 25 are deactivated, the door is opened, the magazine is withdrawn, and the operative cycle finishes.

1189361

When putting into practice the equipment here described and exemplified, modifications and/or improvements can be introduced. All of them must be regarded as performance variations included within the scope of protection of the present application. This scope is 5 determined, in its fundamental aspects, by the text of the claims that follow.

The embodiments of the invention in which an exclusive property or privilege is claimed are defined as follows:

1. Equipment for welding end caps to nuclear fuel rods, comprising: means defining a main chamber having two vertical and parallel faces and containing a rod supporting magazine having an axis perpendicular to the mentioned vertical faces; wherein said magazine is formed by a cylindrical drum having bases which protrude as crowns of the drum cylindrical surface; peripherically, said drum presents two cylindrical surfaces which contact by friction the corresponding seats of both rod butts, as they are placed between protrusions, as crowns of said bases, and the said mean rod butt rings for initial positioning; a quantity of $2n$ guide-rods rigidly linked to the crown-like protrusions of the bases which axis are regularly arranged on a cylindrical surface as generators; several $2n$ rod-supports, each of which is linked in an axially sliding way to each of the named guide-rods, and present a contention elastic mean that can be linked to a discontinuous part of the cylindrical drum outer surface, at the same distance from the bases; each of these rods supports present two elastic clamps oriented in a divergent radial way with respect to the cylindrical drum axis, each of these rod-bearers being able to support each of several $2n$ rods placed separately between the rod butt rings; each rod butt ring presents on one side, a positioning butt to avoid the corresponding rod butt ring from being dragged by the cylindrical drum turn, and on the other side two slots spread 180° among them, each one can, while the rod butt end is in position, let one from the several rods pass when the corresponding rod bearer displaces over the corresponding guide-rod; the cylindrical drum presents, axially, a dragging shaft; the main chamber presents a centering axis linked to one of its vertical faces, and a

tailstock linked to its other vertical face; the centering axis and the tailstock lined up with the magazine axis can be linked to the dragging shaft ends of the cylindrical drum due to the movements of a pneumatic cylinder that is out of the main chamber; the centering axis is linked to an indexing plate that make the magazine turn by angular steps of $\frac{180^\circ}{n}$; the main chamber presents an opening enabling the magazine pass and is linked to a door having sealed devices; two welding enclosures respectively abutted to the two vertical faces and communicated with the main chamber through two first holes lined up with the two slots of the magazine rod butt rings; two pneumatic cylinders for displacing rods which are abutted to the two vertical faces and present two stems which penetrate into the main chamber through two second holes lined up with the slots of the magazine rod butt rings and placed in vertical faces opposite to the corresponding first holes; these stems present rod dragging clamps at both ends; the welding chambers have welding devices and end caps feeding devices; the main chamber has two positioning pneumatic cylinders which stems can link themselves to both positioning butts of the magazine rod butt rings; the main chamber communicates, through the corresponding ducts, with an inert gas container, with a vacuum pump and with the environmental air through respective valves.

2. Welding equipment as claimed in claim 1, characterized by the initial positioning devices being formed by little balls placed into the corresponding cylindrical cavities of the mentioned rod butt ring pressed by respective compression springs, these little balls being linked to the corresponding seats prepared in cylindric superficial paths of crown-like protrusions of the cylindric drum.

//

A

3. Welding equipment as claimed in claim 1, characterized by the contention elastic device of the rod bearers that are formed by elastic strips and present a groove in its central zone; the discontinuous part of the cylindric drum is formed by a hoop placed in the middle of its outer surface and presents a projection in its central zone that can link itself to the mentioned elastic strip groove.

12

A



A

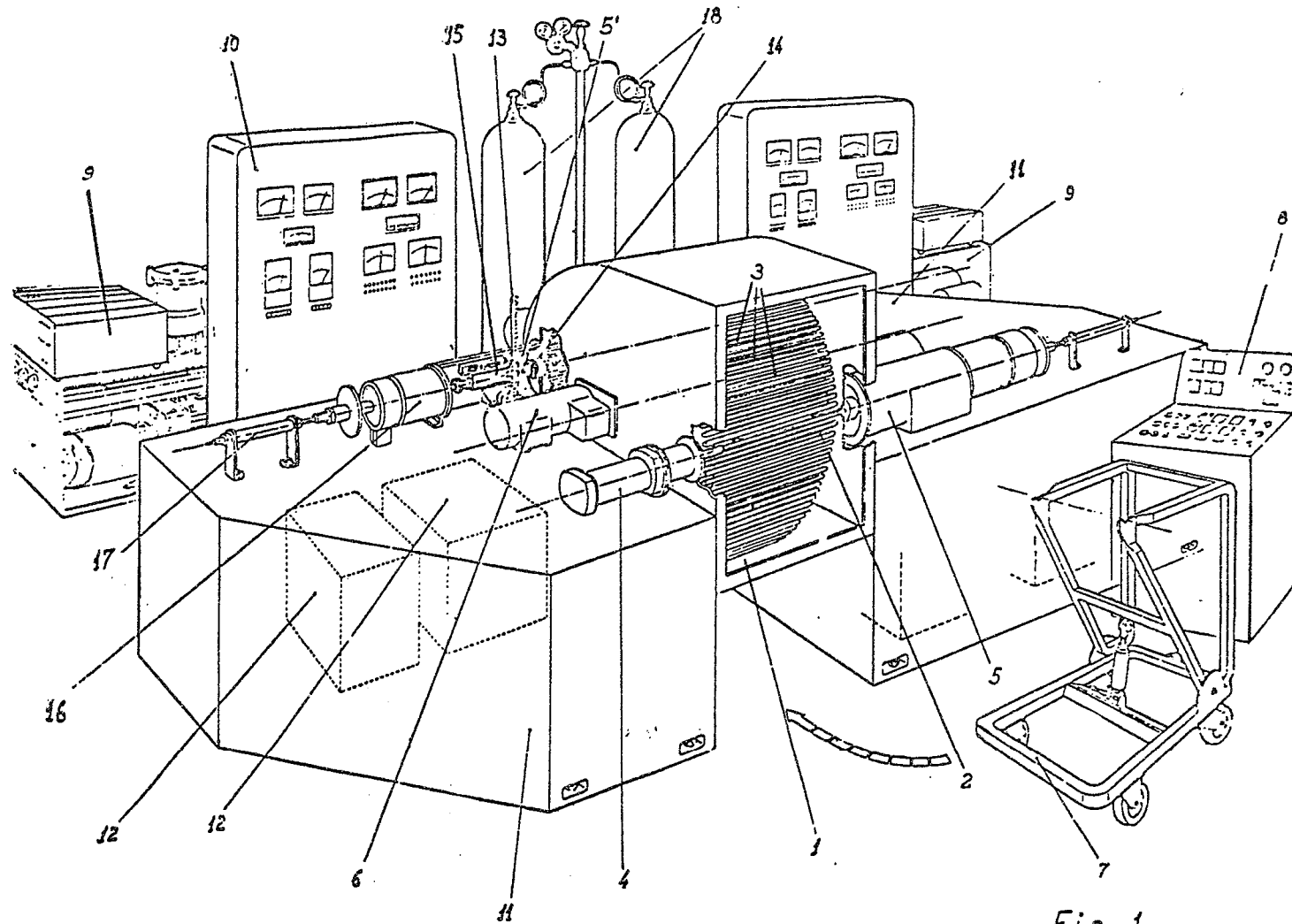

Fig. 1

1189361
3-1-61

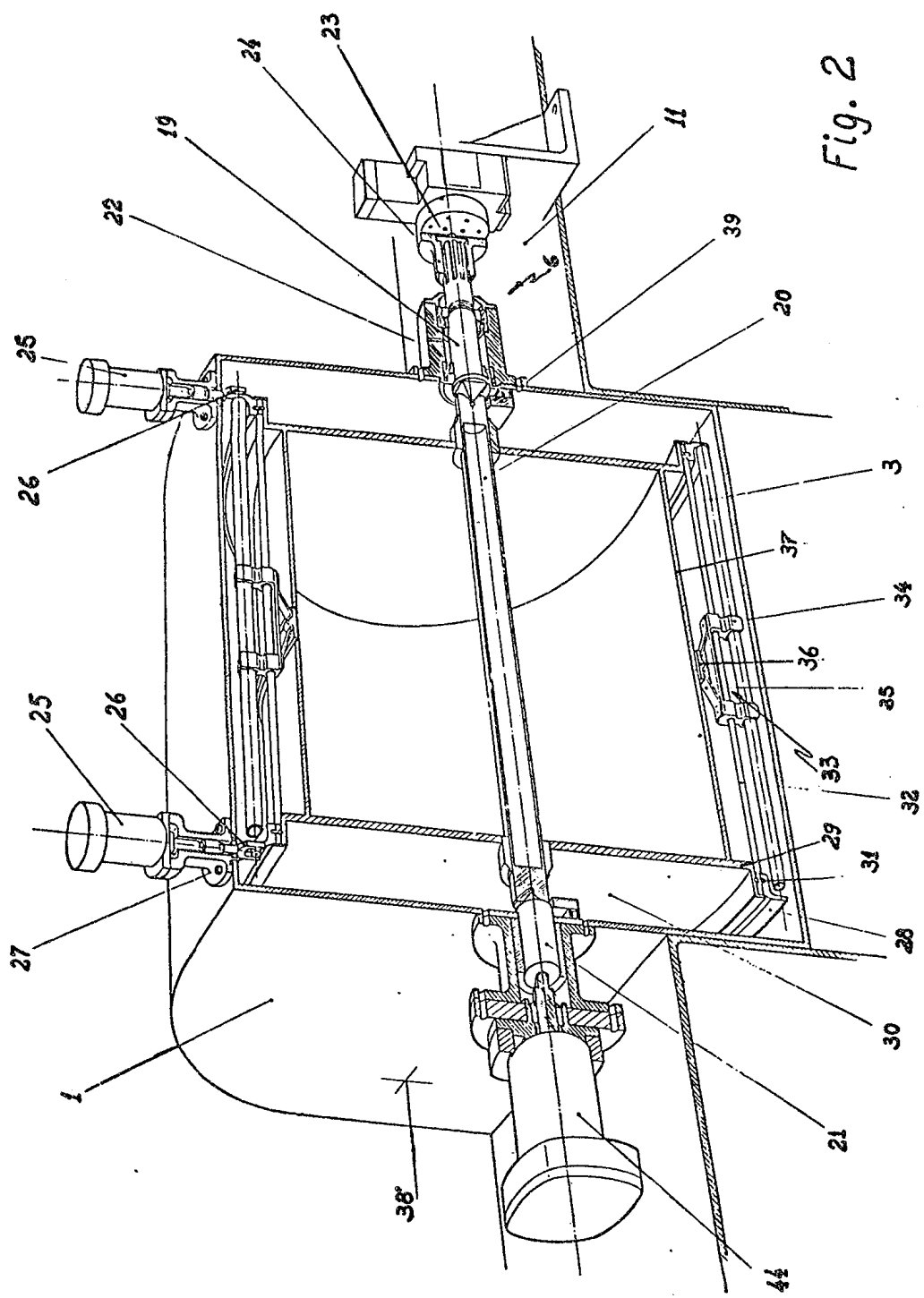

Fig. 2

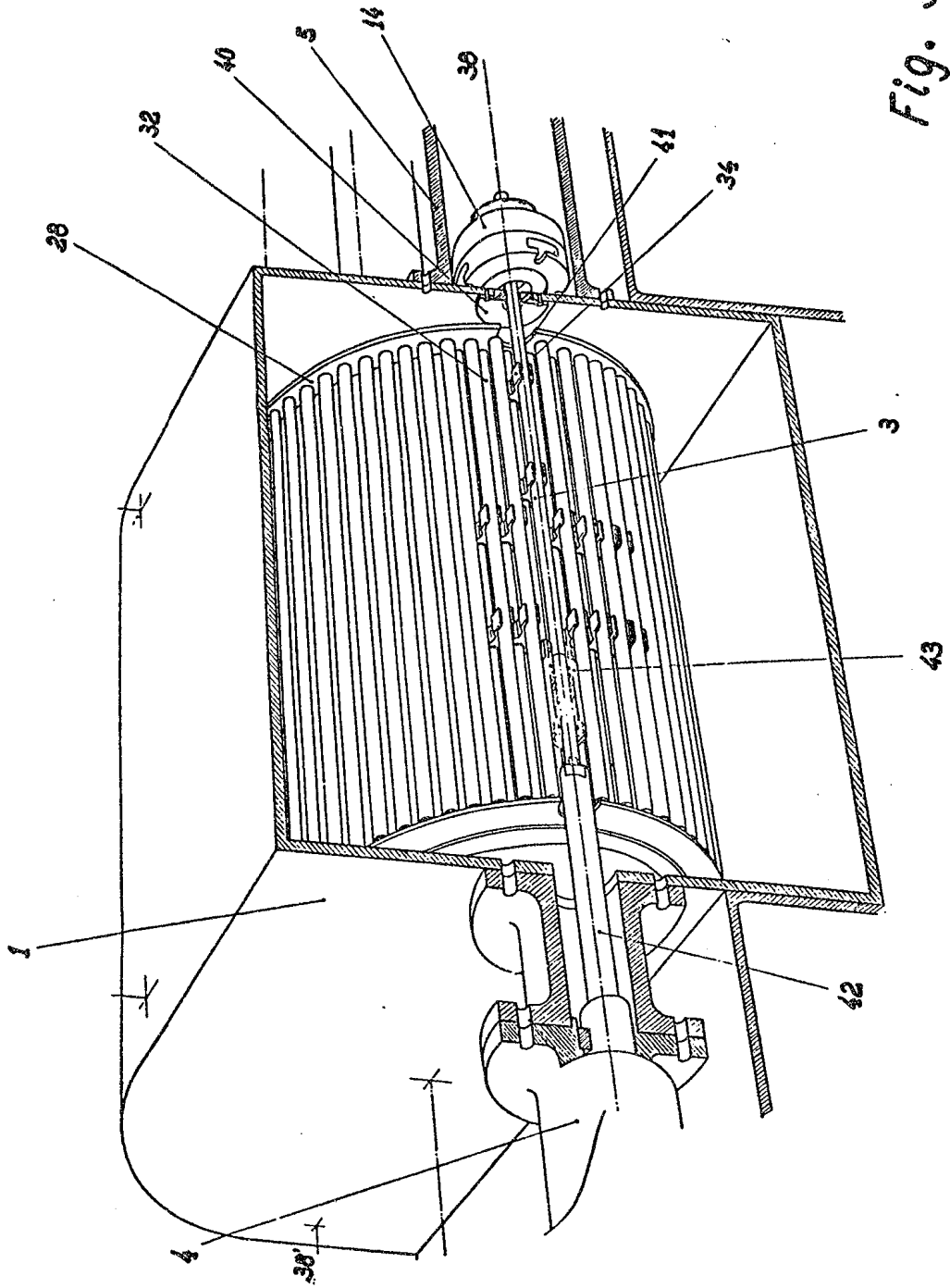

Fig. 3